

---

# Worksurface Acrylic Screens

## Planning Guide

This planning guide will help you determine the right screen size for your work surface.

See how each screen type in a 48" width will fit on a 48" W X 24" D work surface to confirm proportions after the installation.



Single Acrylic Screen Dimensions | **Post Style Bracket**



Single Acrylic Screen Dimensions | **Freestanding Plate**

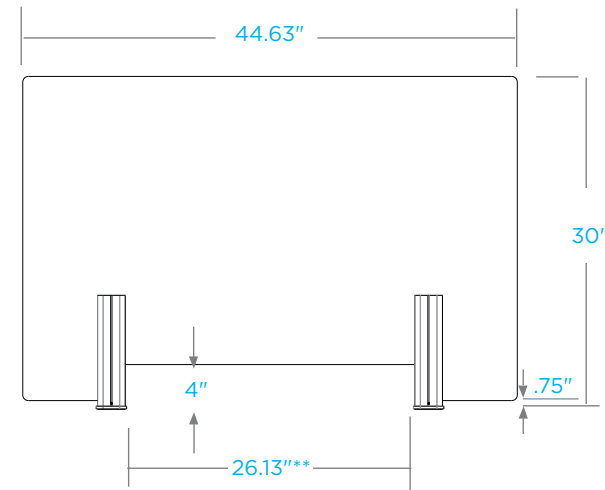
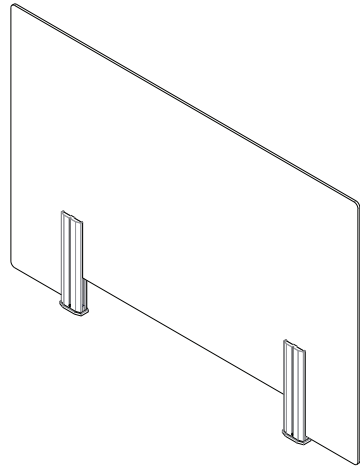

Model SCNSMPS4830  
48"W x 30"H

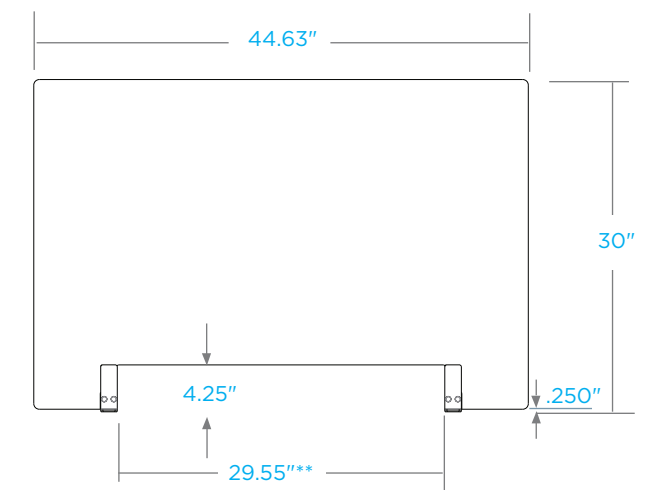
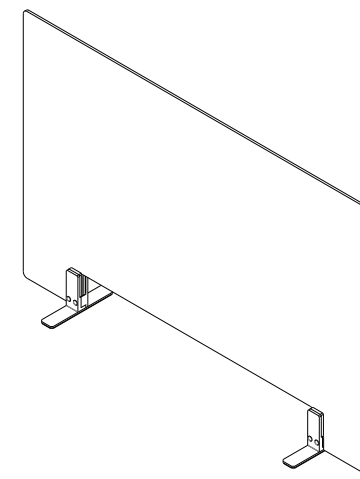
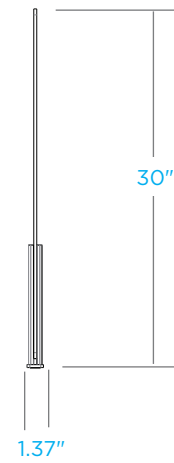

Model SCNAFS4830  
48"W x 30"H

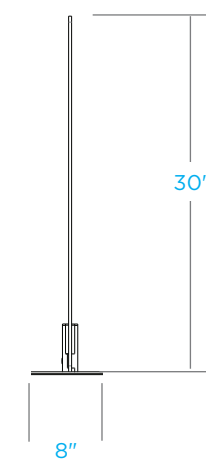

Width of screen	**Width of 4" access slot	Number of brackets
24"	10.13"	2
30"	16.13"	2
36"	22.13"	2
42"	20.13"	2
48"	26.13"	2
54"	32.13"	2
60"	30.13"	2
66"	36.13"	2
72"	42.13"	2

Width of screen	**Width of 4" access slot	Number of brackets
24"	9.55"	2
30"	15.55"	2
36"	21.55"	2
42"	23.55"	2
48"	29.55"	2
54"	35.55"	2
60"	14.19"	4
66"	16.19"	4
72"	18.19"	4



## U-Shape Acrylic Screen Dimensions | Post Style Bracket

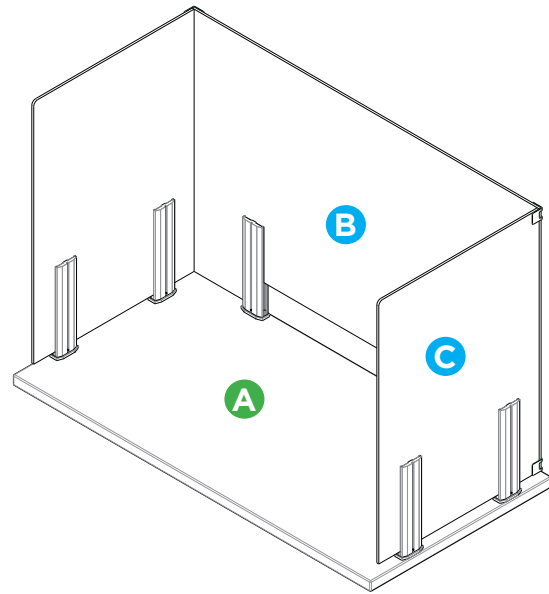

Model SCNSMPU482430  
48"Wx24"Dx30"H

Work surface needs to be a minimum of 45.75"W x 21.43"D to fit this screen model.

All screen dimensions are identical between adhesive and screw mounting methods.

(Corner connectors are applied to the exterior corners.)

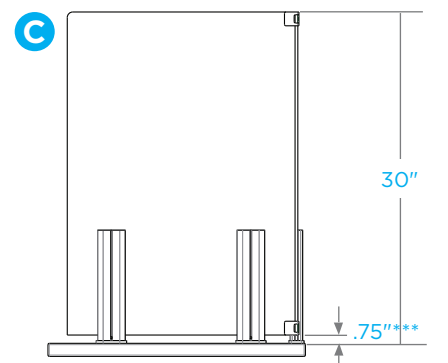
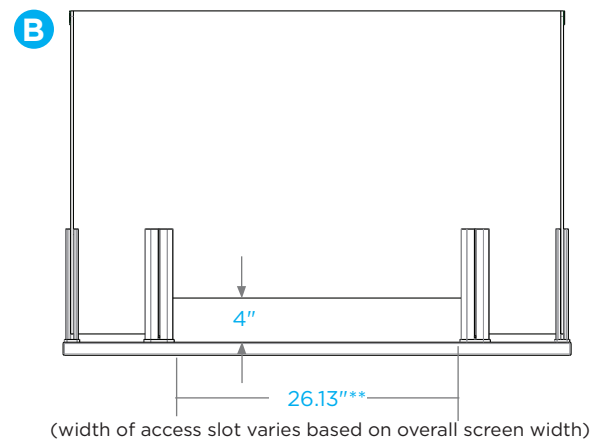
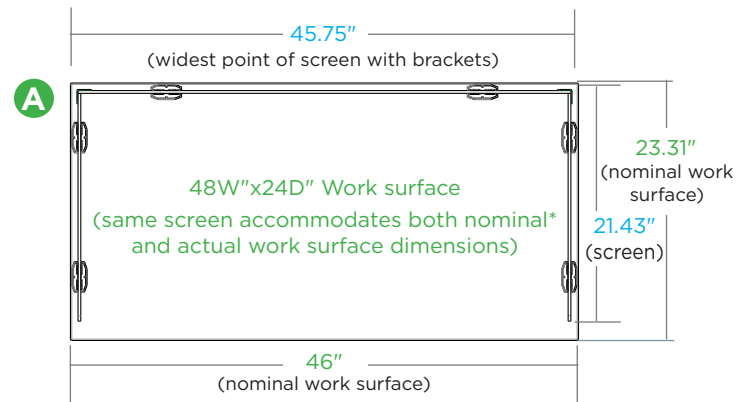

\*\*\*This dimension is 2" on the 2" gap option

Width of screen	**Width of 4" access slot	Number of brackets
36"	22.13"	6
42"	20.13"	6
48"	26.13"	6
54"	32.13"	6
60"	30.13"	6
66"	36.13"	6
72"	42.13"	6



## U-Shape Acrylic Screen Dimensions | Low Profile Bracket

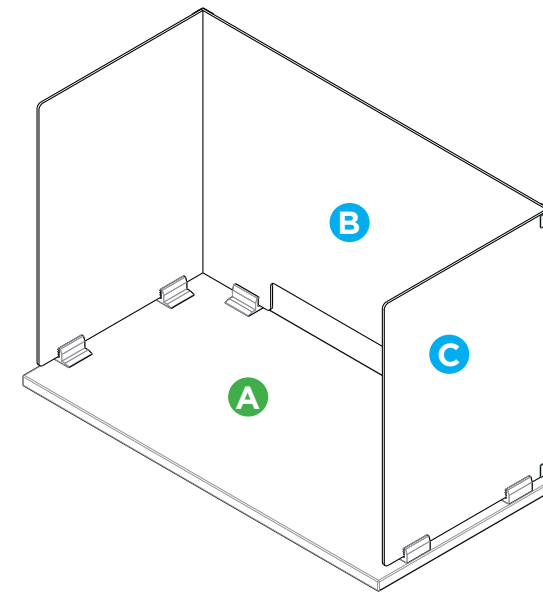

Model SCNTDMU482430  
48"Wx24"Dx30"H

Work surface needs to be a minimum of 45.75"W x 21.87"D to fit this screen model.

(Corner connectors are applied to the exterior corners.)

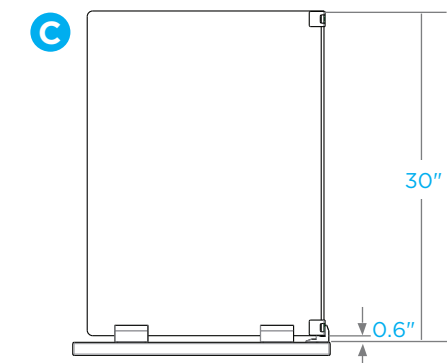
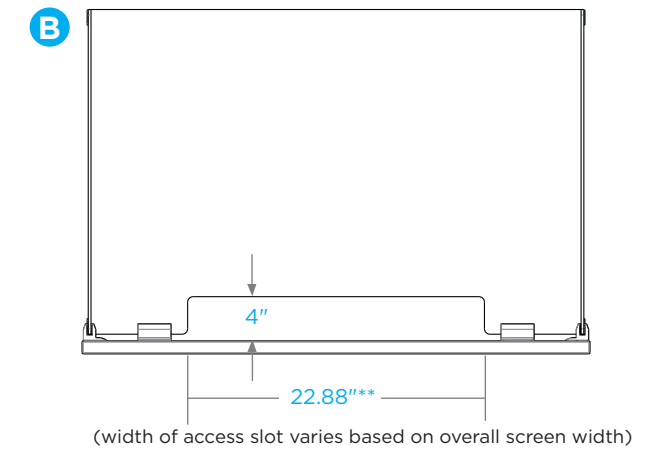
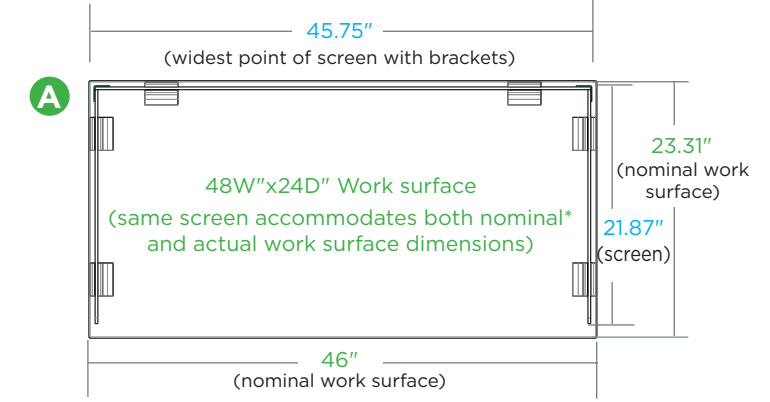

Width of screen	**Width of 4" access slot	Number of brackets
36"	18.88"	6
42"	16.88"	6
48"	22.88"	6
54"	28.88"	6
60"	26.88"	6
66"	32.88"	6
72"	38.88"	6

\*Nominal size tops are Trendway Height Adjustable Table standard sizes



# U-Shape Acrylic Screen Dimensions | Edge Mount Clamp

## On Nominal\* Sized Work Surface

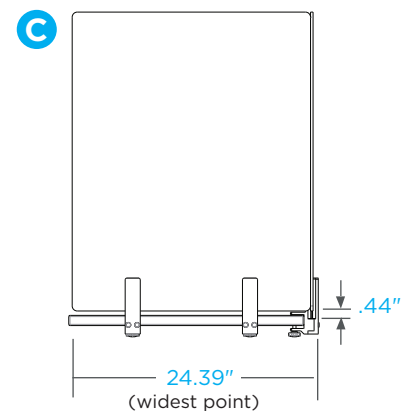
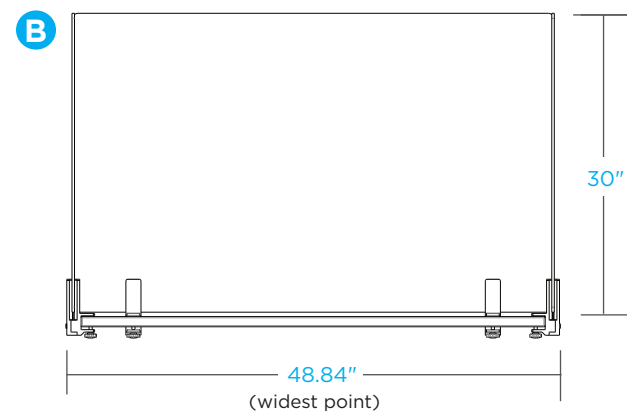
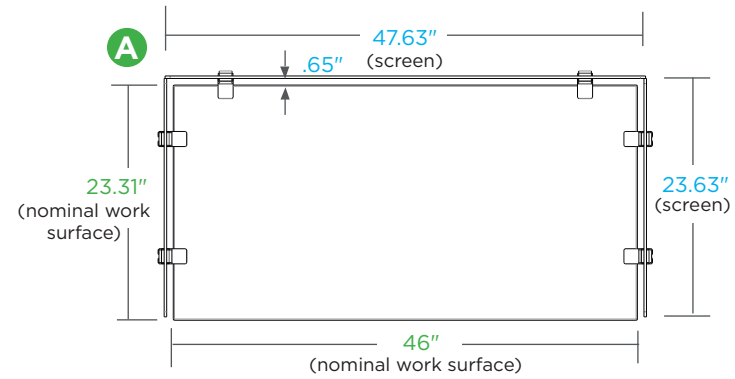
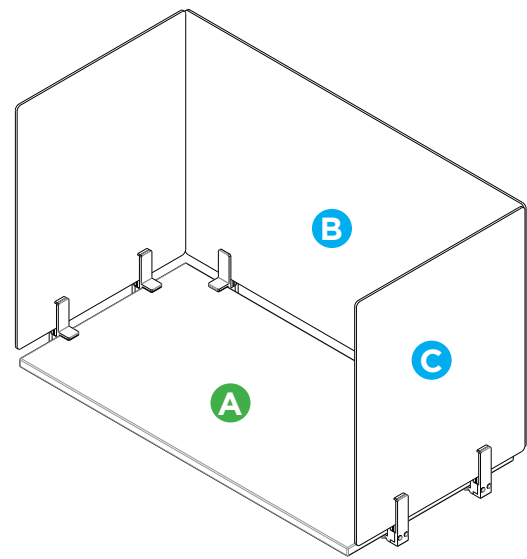

Clamp mount screens are sold as single panels. This U-shape uses these single panel products to create this configuration for a 48"W x 24"D nominal\* or actual work surface size:

- 1 x SCNBECMS4830, 48"W x 30"H
- 2 x SCNBECMS2430, 24"W x 30"H
- 1 x SCNCCK2 Corner Connector Kit (applied on interior corners)

## On Actual Sized Work Surface

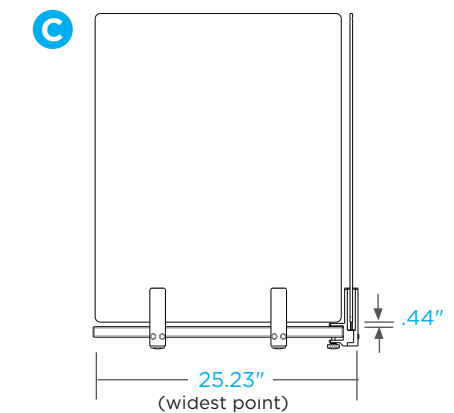
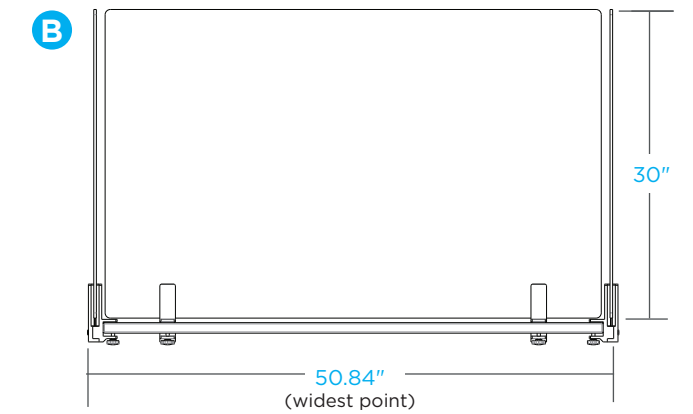
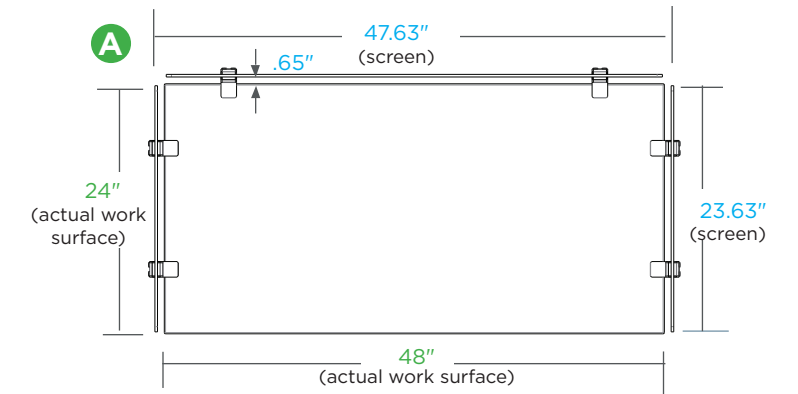
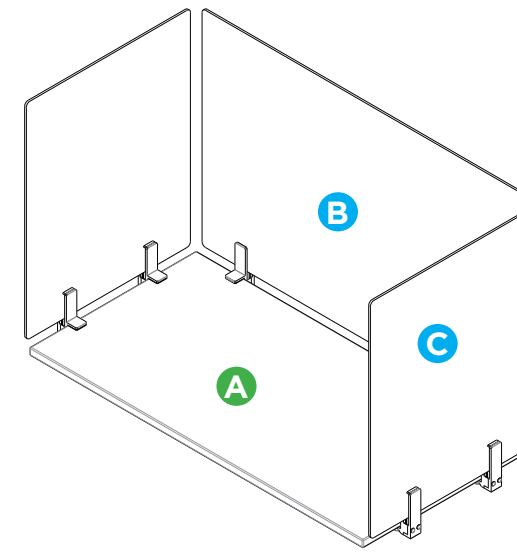

Clamp mount screens are sold as single panels. This U-shape uses these single panel products to create this configuration for a 48"W x 24"D nominal\* or actual work surface size:

- 1 x SCNBECMS4830, 48"W x 30"H
- 2 x SCNBECMS2430, 24"W x 30"H
- 1 x SCNCCK2 Corner Connector Kit (applied on interior corners)

\*Nominal size tops are Trendway Height Adjustable Table standard sizes

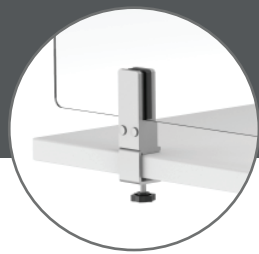

# U-Shape Acrylic Screen Dimensions | Top Mount Clamp

## On Nominal\* Sized Work Surface

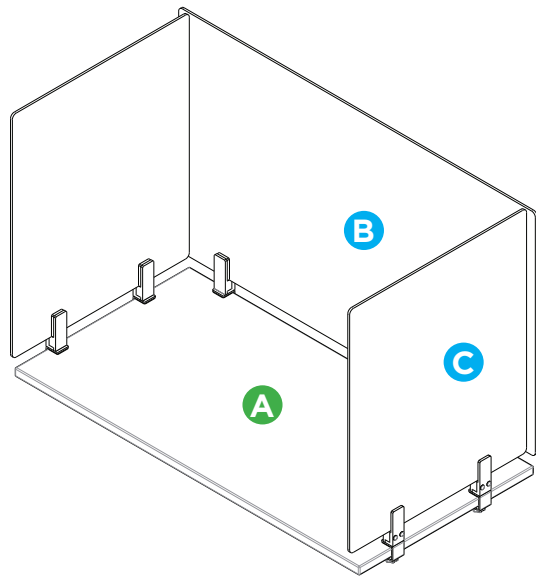

Clamp mount screens are sold as single panels. This U-shape uses these single panel products to create this configuration for a 48"W x 24"D nominal\* or actual work surface size:

- 1 x SCNDTCMS4830, 48"W x 30"H
- 2 x SCNDTCMS2430, 24"W x 30"H
- 1 x SCNCCK2 Corner Connector Kit (applied on interior corners)

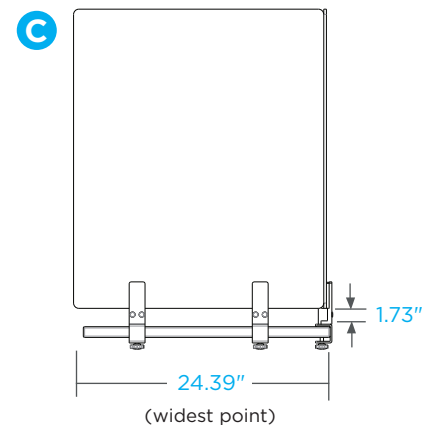
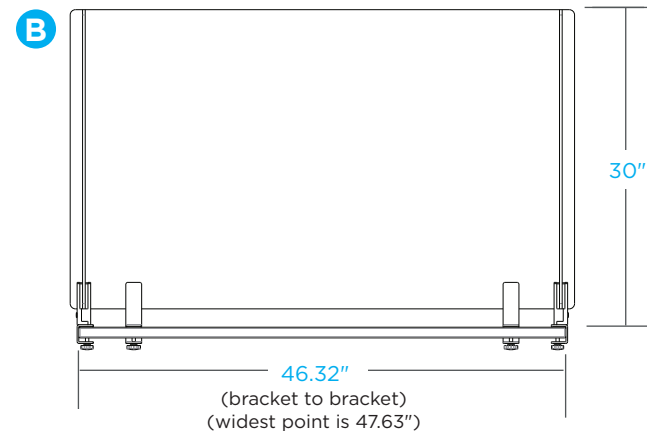
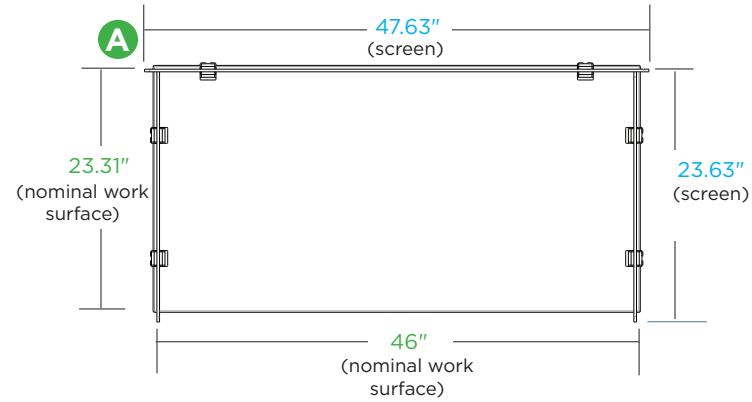

## On Actual Sized Work Surface

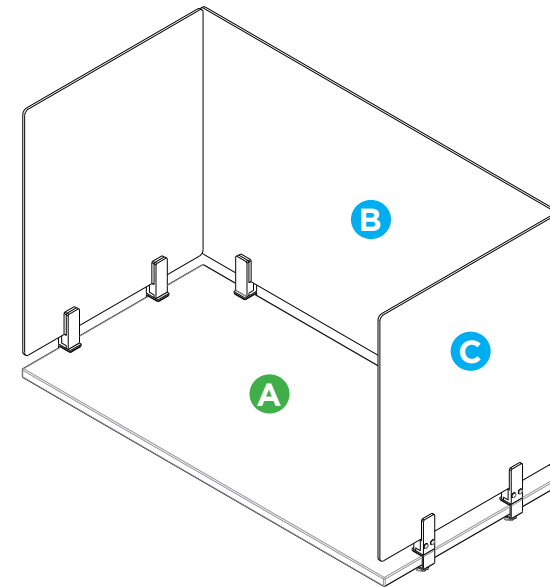

Clamp mount screens are sold as single panels. This U-shape uses these single panel products to create this configuration for a 48"W x 24"D nominal\* or actual work surface size:

- 1 x SCNDTCMS4830, 48"W x 30"H
- 2 x SCNDTCMS2430, 24"W x 30"H
- 1 x SCNCCK2 Corner Connector Kit (applied on interior corners)

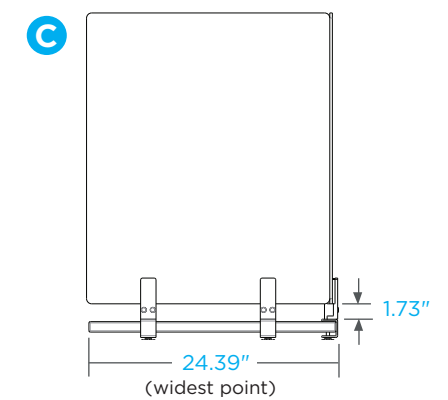
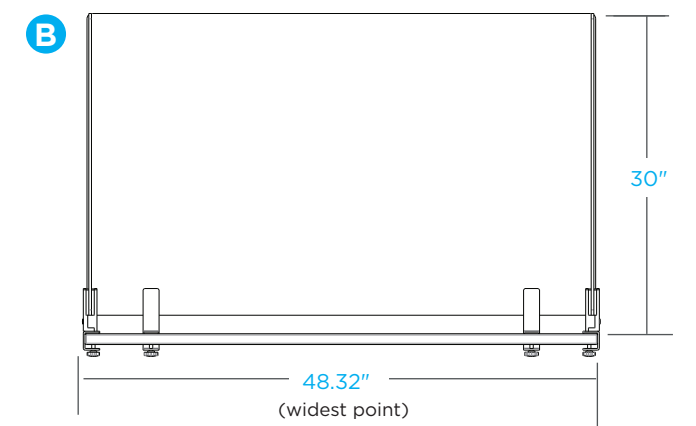
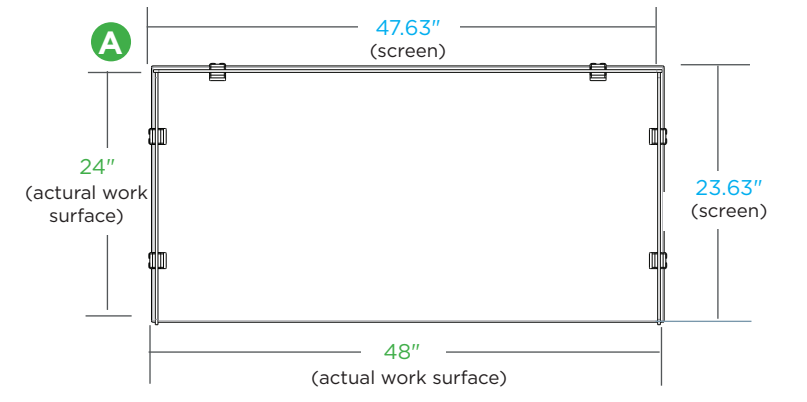

\*Nominal size tops are Trendway Height Adjustable Table standard sizes

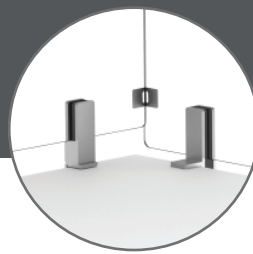

# Acrylic Screen Dimensions | Combination Mount Clamp

## On Nominal\* Sized Work Surface

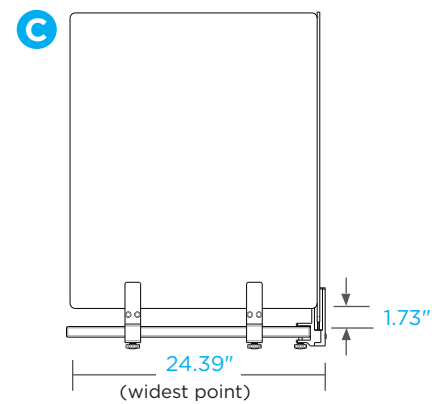
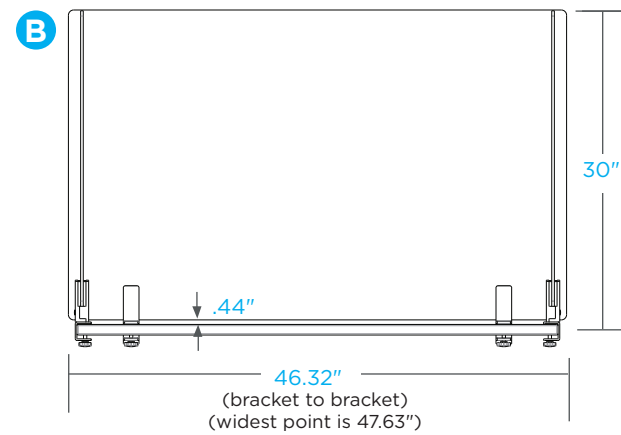
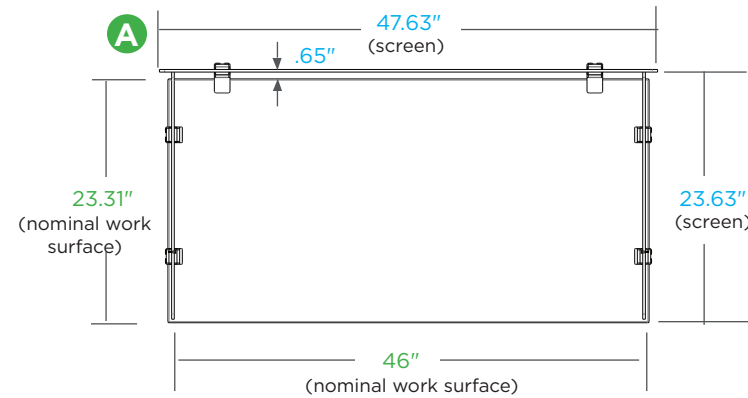
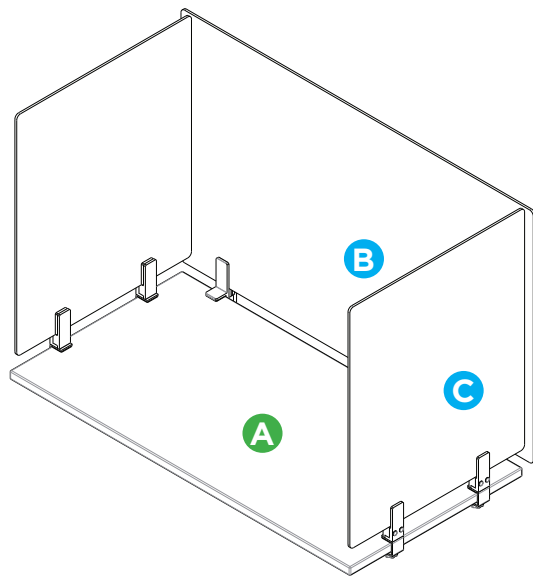

Clamp mount screens are sold as single panels. This U-shape uses these single panel products to create this configuration for a 48"W x 24"D nominal\* or actual work surface size:

- 1 x SCNBECMS4830, 48"W x 30"H
- 2 x SCNDCMS2430, 24"W x 30"H
- 1 x SCNCCK2 Corner Connector Kit (applied on interior corners)

It is recommended that the edge mount clamp be used along the back edge of the worksurface (for monitor arms, wire management, etc.), and the top mount clamp be used along the sides (to accommodate adjacent worksurfaces without interference).

## On Actual Work Surface

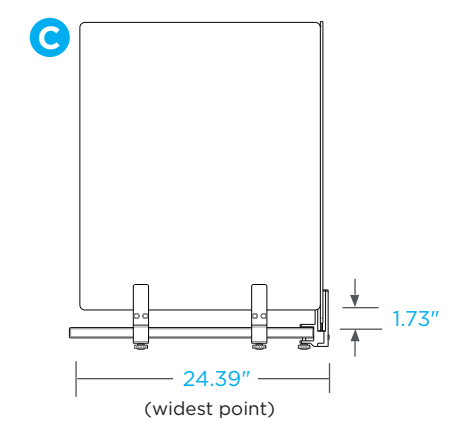
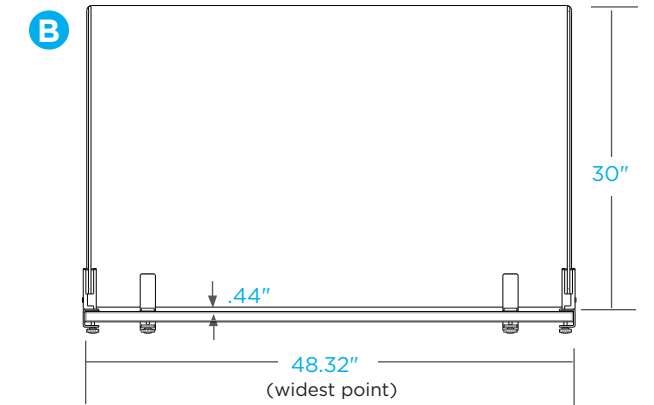
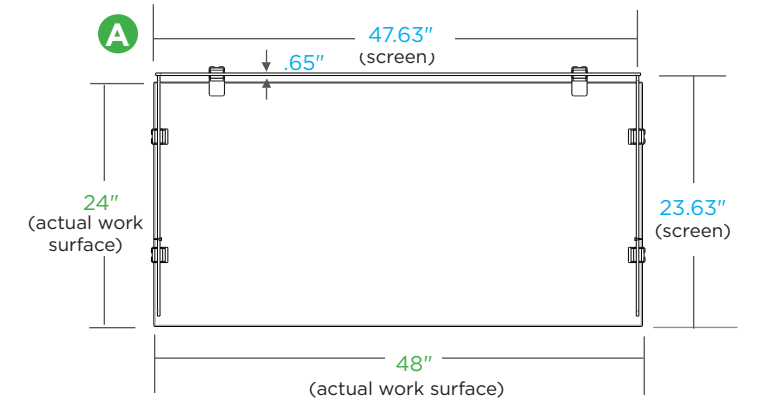
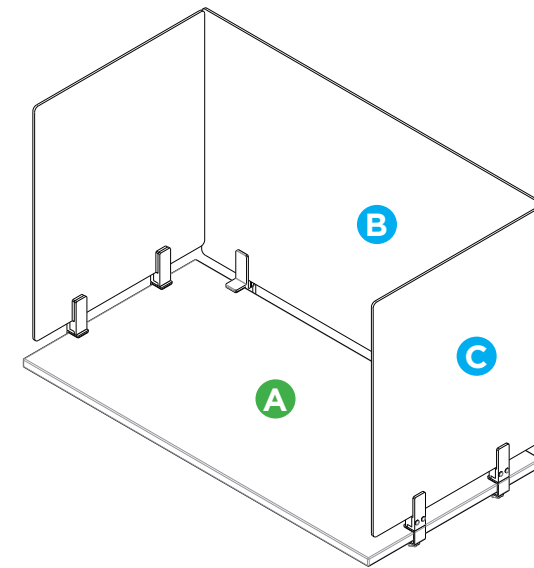

Clamp mount screens are sold as single panels. This U-shape uses these single panel products to create this configuration for a 48"W x 24"D nominal\* or actual work surface size:

- 1 x SCBECMS4830, 48"W x 30"H
- 2 x SCNDCMS2430, 24"W x 30"H
- 1 x SCNCCK2 Corner Connector Kit (applied on interior corners)

It is recommended that the edge mount clamp be used along the back edge of the worksurface (for monitor arms, wire management, etc.), and the top mount clamp be used along the sides (to accommodate adjacent worksurfaces without interference).

\*Nominal size tops are Trendway Height Adjustable Table standard sizes

## Acrylic Screens | Cleaning Instructions

**First time setup:** Do not attempt to clean immediately after removing the protective paper because the static electricity will attract dust and particles. Wait a day for the static to dissipate before cleaning.

### Step 1

Begin by removing excess dust or dirt from the surface of the acrylic with an air hose or blow dryer set to its coolest setting (never heat acrylic). Hold the blow dryer at a 45-degree angle several inches away from the acrylic and run side-to-side down the surface. Wipe any remaining dust with a soft, lint-free cotton microfiber cloth.

### Step 2

Once excess grime has been blown away, spray a nonabrasive acrylic cleaner, such as Brilliance or Novus No. 1 onto a one- or two-foot-square section of acrylic. (For an on-hand alternative, a solution of mild dish soap and water works well too.). Never use abrasive cleaners or anything containing Ammonia such as Formula 409®, Windex® or Fantastik®. Ammonia will cause your acrylic to get cloudy and you can't reverse the effects. Bleach solutions and disinfectants are not recommended and can cause damage to the acrylic.

Once the cleaner has been applied, use a soft, lint-free cotton microfiber cloth to gently wipe the surface down, again being careful to make contact only with the portion of the surface that already has cleaner on it. Continue applying the cleaner and wiping it off in small sections until you've finished the entire surface. Do not use a paper towel to clean acrylic because it can cause scratching.

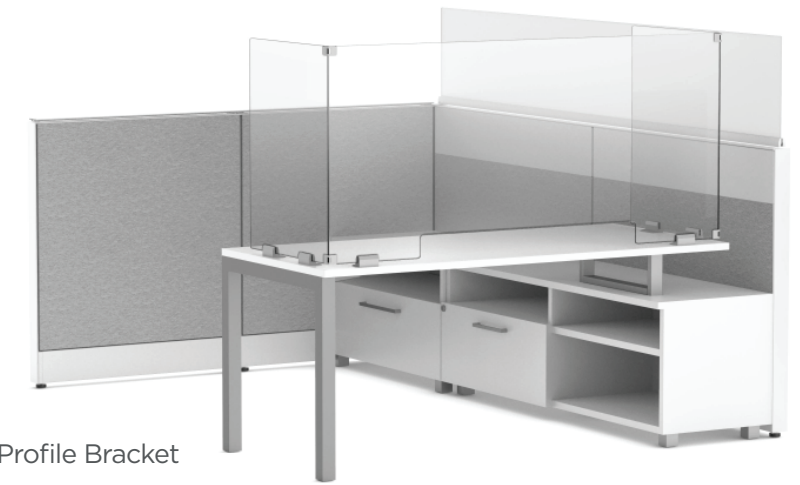

Low Profile Bracket



Edge Mount Clamp



Top Mount Clamp

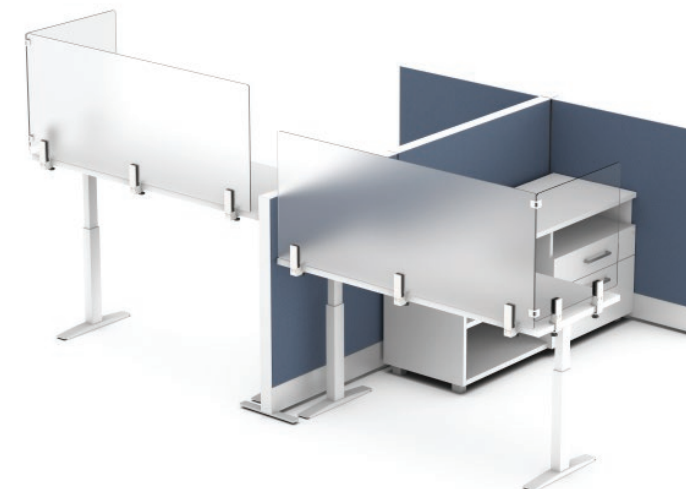

Mixed Combination Clamp



Post Style Bracket



Freestanding



---

Trendway >

**Fellowes** | FAMILY BUSINESS  
Brands. SINCE 1917

HEADQUARTERS | Holland, Michigan | 616.399.3900

CHICAGO | LOS ANGELES | WASHINGTON, DC

Trendway.com | April 2021